

## Animal Eyes

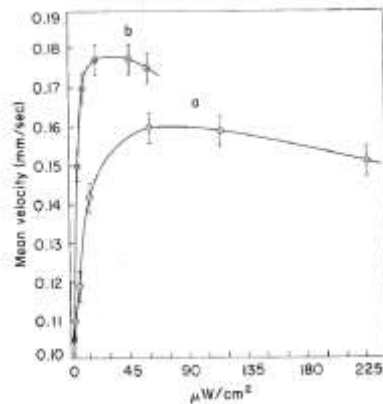
We can learn a lot from the wonder of, and the wonder in, animal eyes. **Aldo Leopold** a pioneer in the conservation movement did. He wrote in *Thinking like a Mountain*, “We reached the old wolf in time to watch a fierce **green fire** dying in her eyes. I realized then, and have known ever since, that there was something new to me in those eyes – something known only to her and to the mountain. I was young then, and full of trigger-itch; I thought that because fewer wolves meant more deer, that no wolves would mean hunters’ paradise. But after seeing the **green fire** die, I sensed that neither the wolf nor the mountain agreed with such a view.” For Aldo Leopold, the green fire in the wolf’s eyes symbolized a new way of **seeing** our place in the world, and with his new **insight**, he provided a new **ethical perspective** for the environmental movement. <http://vimeo.com/8669977>



**Light contains information about the environment**, and animals without eyes can make use of the information provided by environmental light without forming an image. *Euglena*, a single-celled organism that did not fit nicely into **Carl Linnaeus’** two kingdom system of classification, quite clearly responds to light. Its plant-like nature responds to light by **photosynthesizing** and its animal-like nature responds to light by **moving** to and staying in the light. Light causes an increase in the swimming speed, a response known as



**photokinesis.** Light also causes another response in *Euglena*, known as an accumulation response (**phototaxis**). The light sensitive *Euglena* cells sense the direction of light, swim quickly towards the light, and stay in the light. The *Euglena* cell can be described as a **light meter**, not unlike the one that we used to test the **inverse square law**. Jerome Wolken (1995) describes *Euglena* as a **photo-neurosensory cell**.



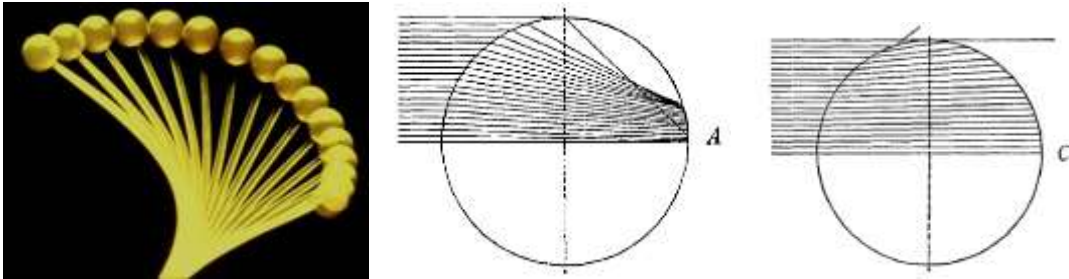
**Demonstration:** See how the *Euglena* cells/organisms accumulate in the light.

Light-induced movements in *Euglena* have been studied by **Jerome Wolken**, the father of Jonathan Wolken, a founding member of the Pilobolus Dance Company, who performs Shadowland. The dance company was named after *Pilobolus*, a light-sensitive fungus growing in Wolken's lab that shoots its spores towards the light. Here is a drawing of *Pilobolus* on the night of November 3, 1911, showing its ability to sense and grow towards the direction of light.

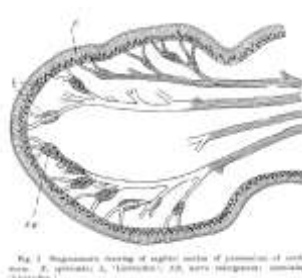


FIG. 12

The single-celled sporangiophore of *Phycomyces*, a fungus similar to *Pilobolus* acts like a light meter/converging lens that, when in air, focuses the light on the back side (A). When *Phycomyces* is grown in a medium that has the same refractive index as the cell, the light is not focused (C) and the sporangiophore does not bend (Castle, 1933)!



Earthworms are also capable of sensing light *without* eyes as reported by Charles Darwin (1881) in his book, *The Formation of Vegetable Mould, through the Action of Worms, with Observations of their Habits*. Earthworms have **light-sensitive photoreceptor cells in and under the skin** throughout their body although they are concentrated in the anterior portion (Hess, 1925). The earthworms are **photophobic** and move away from the light and towards the dark. At dawn, they crawl into their dark holes and stay there until dusk. I wonder if the birds know their schedule.



Some animals have light meter-like “eyes” or **ocelli**, where photoreceptive cells that face the surface are arranged in **pits** or **cup-like patches**. **Pit or cup-like eyes** are found in the mollusc, *Patella vulgata*, which is a limpet that tenaciously attaches to rocks in the intertidal zone shown here on the **Hugh Miller Trail** near the Village of Cromarty Scotland.

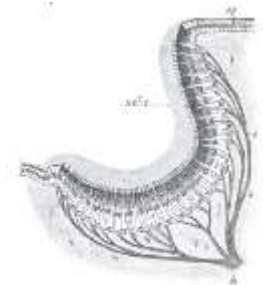
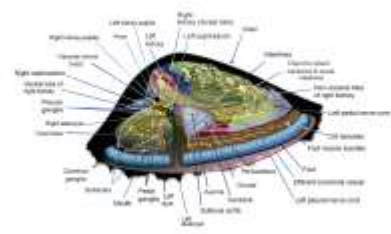
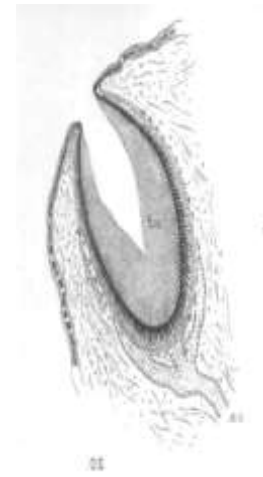


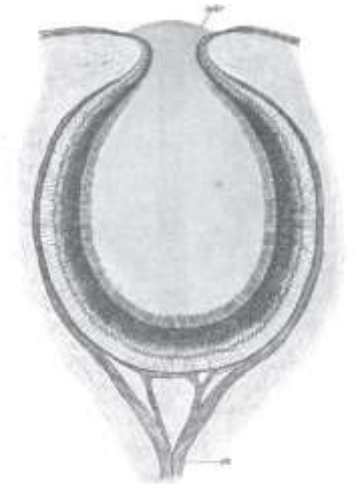
Fig. 1. Eye of a mollusc, showing the structure of the eye, the sclerotic layer, the cornea, the lens, the vitreous body, the retina, and the optic nerve.



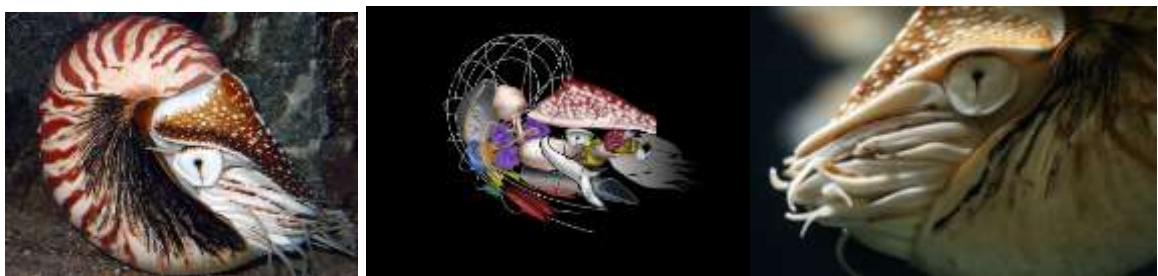
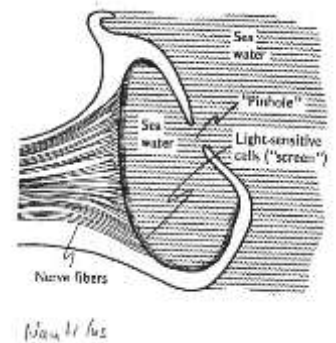
In the living fossil, *Pleurotomaria*, the small and inconspicuous eyes of this mollusc are more sunken. The photoreceptors face into the cavity that forms the optic cup and the ganglia are behind them. The cavity is open and sea water fills the upper portion of the cavity and a vitreous material fills the bottom of the optic cup. The **geometry almost** approaches that of a **pinhole camera**; however, with such a wide aperture relative to the image distance, any object would probably appear as a blob.



The geometry of the eye of the **iridescent mollusc**, *Haliotis* or abalone is more like a **pinhole camera**. The smaller **aperture** and more spherical retina would result in a relatively sharp image and relatively good **visual acuity**. The **tradeoff** of the smaller aperture is that the image will be **dimmer**.



The geometry of the eye of the **cephalopod mollusc**, *Nautilus*, another living fossil, is even more like a **pinhole camera**. The smaller **aperture** and more spherical retina would result in a relatively sharp image and relatively good **visual acuity**. The **tradeoff** of the smaller aperture is that the image will be **dimmer**.

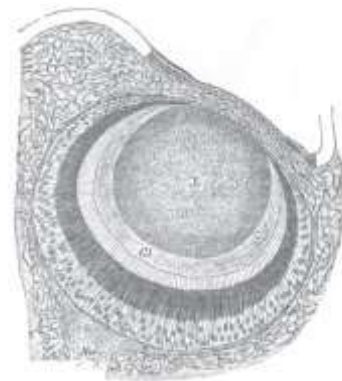


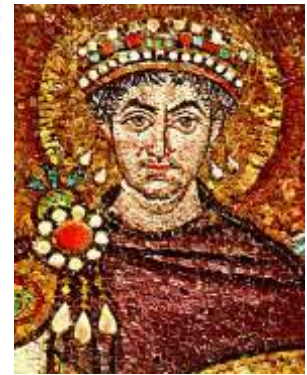
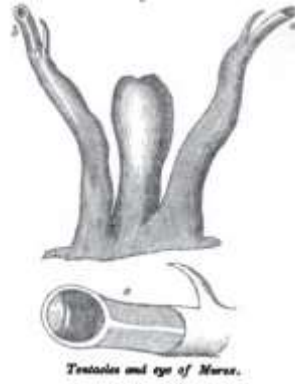
The **pinhole camera eye** of *Nautilus*, trades off dimness for visual acuity. Dimness can be overcome by the addition of a converging lens to make a **camera-like eye**, just as the *camera obscura* was improved by adding a converging lens.



The gelatinous lenses of *Murex* and *Helix* that I will describe below do not have the refracting or dioptric power to produce a focused image on the retina.

*Murex* is a mollusc that lives in the intertidal zone. We will talk about *Murex* later in the semester when I talk about the dyes **Tyrian (royal) purple** and **Tekhelet**. *Murex* has a camera-like eye where the optic cup-like retina is filled with a gelatinous lens that captures a lot of light compared with a pinhole but it probably underfocuses and is not very effective in image formation. *Murex* does have a cornea that interfaces with salt water ( $n= 1.33-1.34$ ) at times and air ( $n = 1$ ) at other times, but because the cornea is so flat it does not have much refractive or dioptric power and does not participate much in image formation.





Other molluscs, such as land snail, *Helix*, have an eye like that of *Murex* that captures a lot of light but is also probably not very effective in image formation.

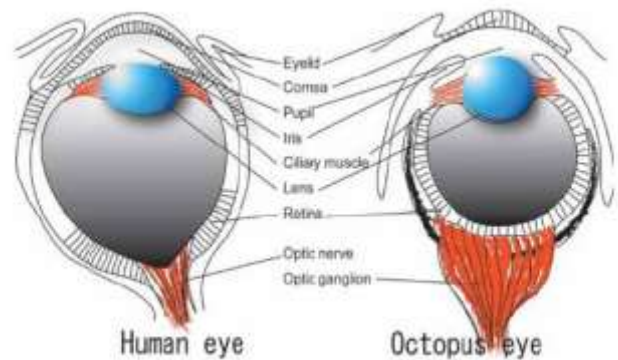


Going back to aquatic animals, some **predatory** animals, such as squid and octopus that live **in the sea** where **light may be limiting** have eyes with the ability to both capture light and to produce a focused image on the retina. A lens that has the ability of **accommodate** mitigates the tradeoff between brightness and visual acuity, although it does introduce aberrations.

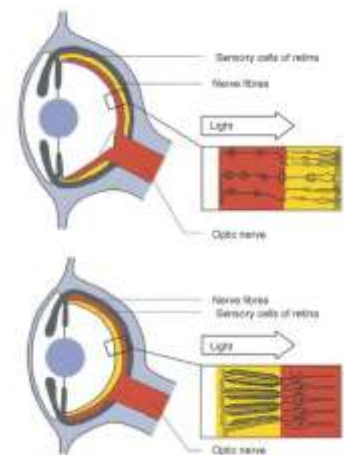


The eye of a **squid** or an **octopus** is similar to the human eye in that it has a **cornea** and a **crystalline lens** to refract light, an **iris** that surrounds a **pupil** that opens in dim light, a **retina** and an **optic nerve**. The visual system is also similar

in that a large part of the **brain** is involved in visual processing. The octopus and squid eyes differ in that the human eye **accommodates** by changing the shape of the **crystalline lens**, becoming more convex when focusing nearby objects whereas the octopus eye, like a camera, **accommodates** by moving the crystalline lens farther from the retina when focusing nearby objects.



There is also a difference in the organization of the **retina** in the human and octopus eye. In the human retina, except at the fovea, the photoreceptor cells are at the far side of the incoming light and the neural cells are on the near side. This by necessity results in a blind spot. In the octopus, the photoreceptor cells are at the near side of the incoming light and the neural cells are on the far side. Consequently, there is no blind spot.



The giant or colossal squid is about 4.2 meters long and lives 1000 meters beneath the sea. The large soccer ball-sized eye, orange-sized lens, and its 8-9 cm in diameter pupil, results in a large light gathering capacity that helps the giant squid see in deep waters. Humans can only see in waters 500-600 meters down. The giant squid eye also has **photophores** that contain **bioluminescent bacteria**

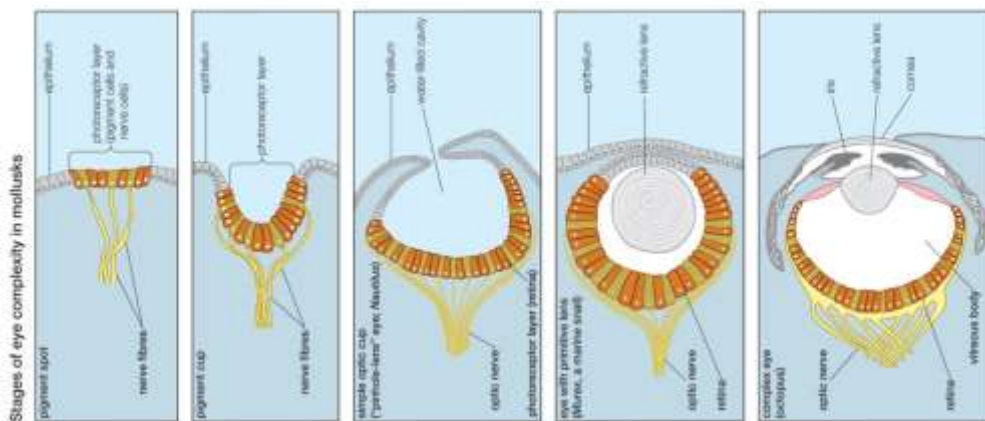


help the giant squid to see in deep waters.

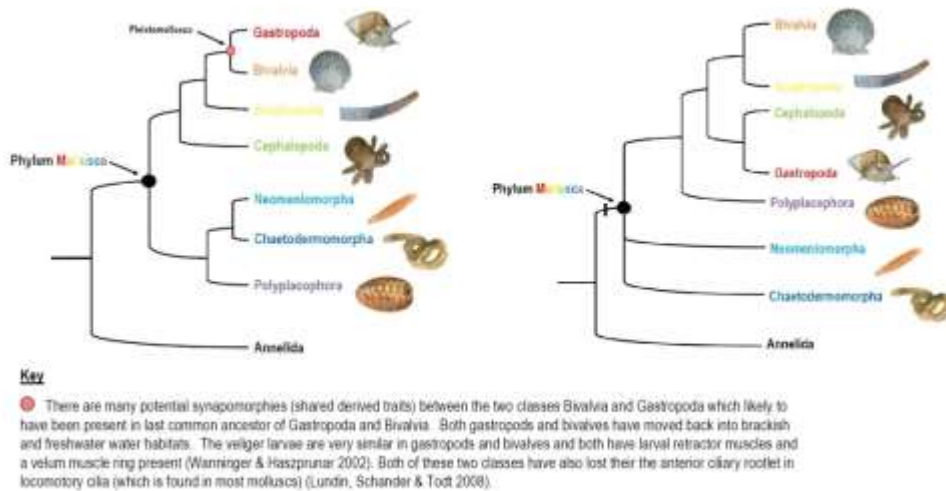
<http://squid.tepapa.govt.nz/anatomy/article/the-eye-of-the-colossal-squid>



The levels of complexity of the molluscan eye from a **light-meter eye**, through a **pinhole camera eye** to a **camera eye** are summarized in the figure below.



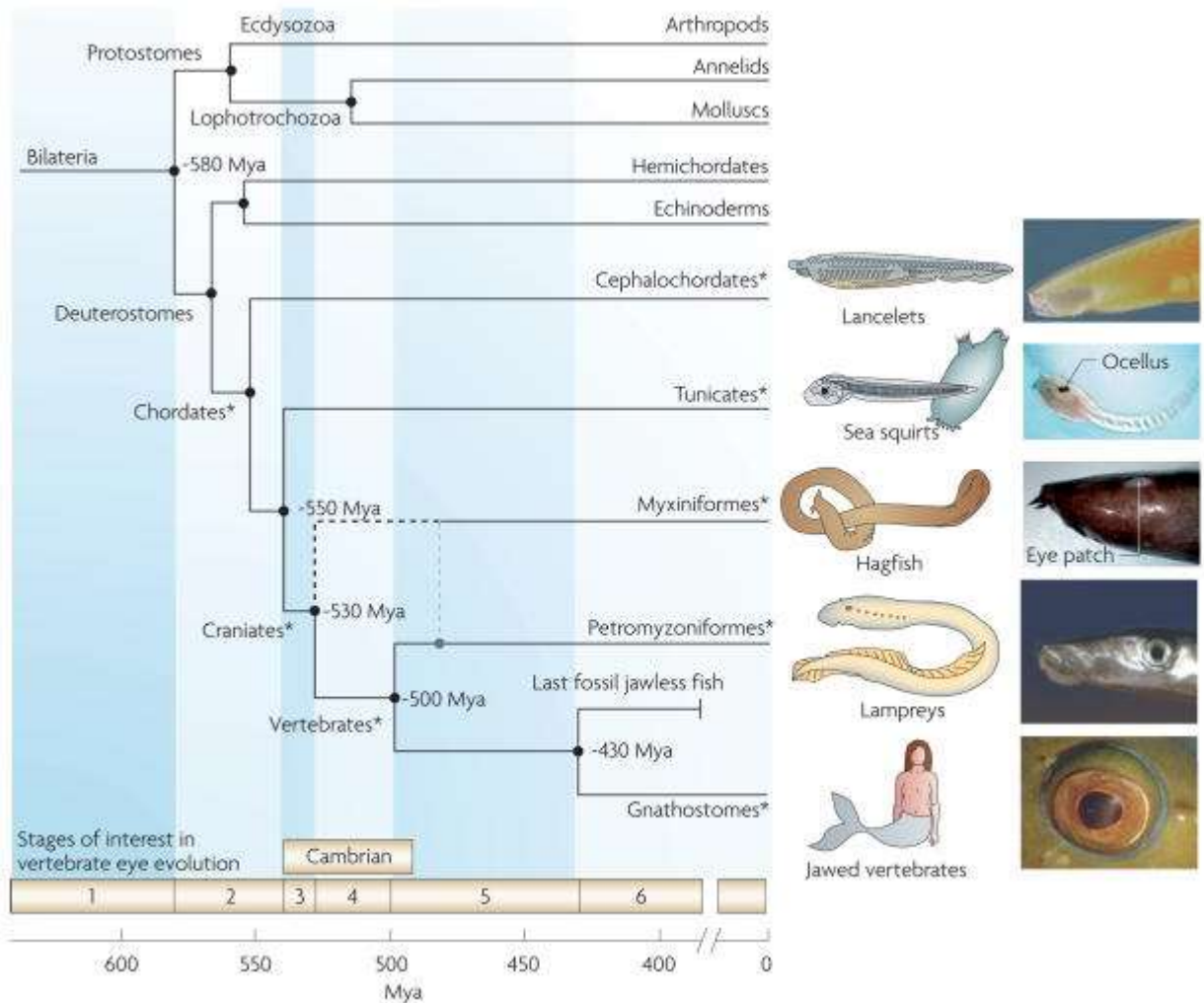
Potential evolutionary relationships between these organisms are given below:



Let's look at the eyes of **chordates**, including hagfish, lampreys and other vertebrates, the ancestors of which existed at the time of the **Cambrian explosion** about 543 million years ago. Chordates are bilaterally symmetrical and possess a notochord, which is a support structure that develops into the backbone in vertebrates.

I am considering **time to be real and unidirectional**. This is not a common belief nowadays. To quote an anonymous reviewer of one of my recent papers (2/7/15): *“I’m worried that the author is addressing a non-problem. Even if time’s arrow is not real, there still may be local time asymmetries – in the same way as organisms constitute local violations of the law of increasing entropy.”*

In *In the Blink of an Eye: How Vision Sparked the Big Bang of Evolution* and *Seven Deadly Colours: The Genius of Nature’s Palette and How it Eluded Darwin*, Andrew Parker suggests that the rapid diversification of animals that took place in the Cambrian was a result to the evolution of eyes which led to intense predation and the ability to escape it.



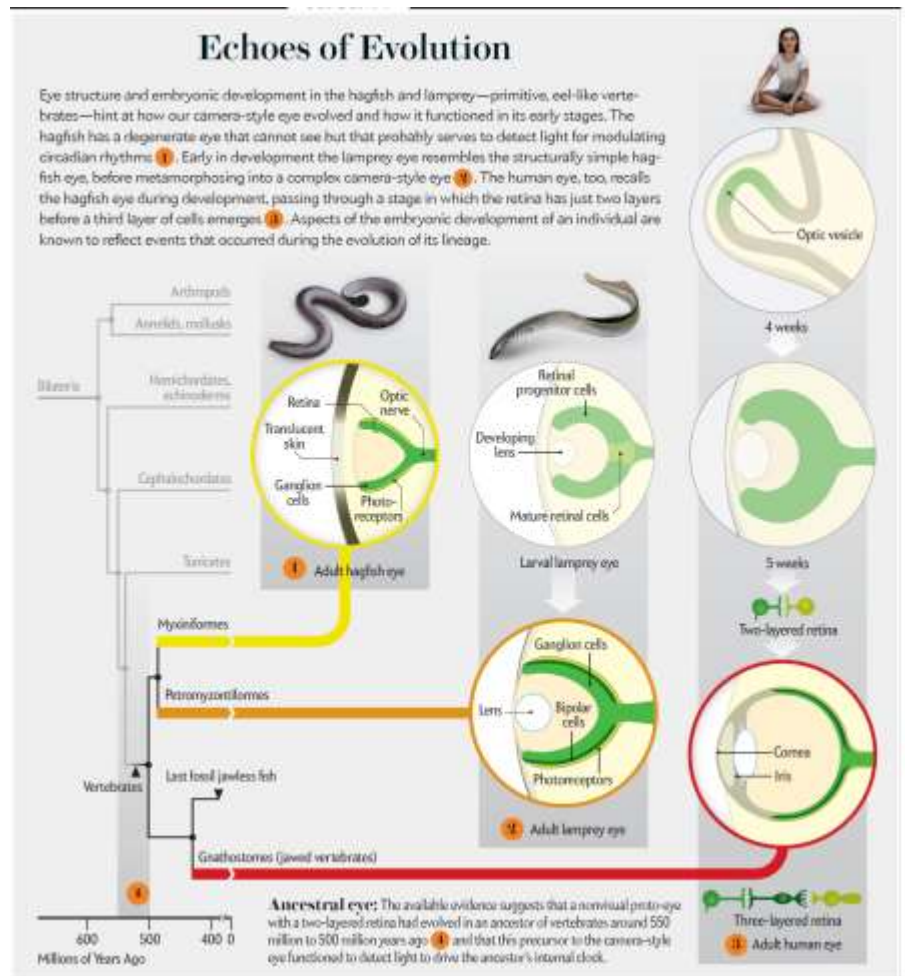
The **hagfish** is a slime secreting, jawless eel-like living fossil that has a notochord but lacks vertebrae. It may be more primitive than lampreys or may have degenerated from lampreys (Lamb et al, 2007). The hagfish eye is **small and buried behind a patch of translucent skin**. It cannot form an image since it lacks a cornea, an iris, a pupil (or pinhole) and a crystalline lens. Moreover, the photoreceptors in the retina do not connect to bipolar cells but connect directly to ganglion cells, which go to the hypothalamus, a part of the brain that is in part involved with circadian rhythms.



The **lamprey** is also an eel-like jawless fish that has a notochord and lacks vertebrae. Unlike the hagfish, the lamprey has large eyes. The **eyes** of the adult lamprey are similar to human eyes, while the eyes of the larvae are reminiscent of the hagfish eye, which is unable to produce an image. Von



Baer suggested that the **developmental stages through which the embryo passes** might reflect the **evolutionary history** of that organism. Even though natural selection could act on any stage of embryo development, it would be more life-threatening to change an earlier process than to add on a process later in development. Similar embryology may be a reflection of **common descent**.

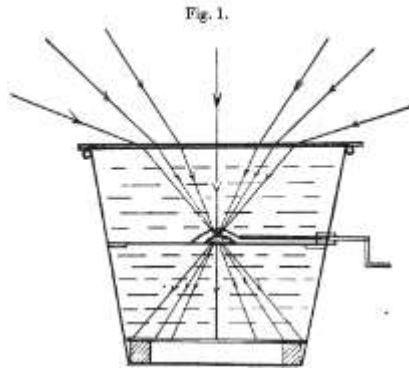


**Fish** are aquatic vertebrates whose eyes differ from eyes of terrestrial organisms because water differs from air. Compared to terrestrial vertebrates, fish lenses are denser and more **spherical**. This is because the refractive index of water is close to the refractive index of the cornea



and consequently, the cornea has little refracting or dioptric power and the **crystalline lens provides the majority of the dioptric power of a fish eye**. Unlike human eyes, the crystalline lens in the eyes of fish is typically **spherical** with a **short focal length that focuses near objects on the retina when the muscles are relaxed**. When the inelastic, rigid fish eye **accommodates** it does *not* change shape. The crystalline lens moves toward the retina so that distant objects become focused. The **size of the pupil** of a fish's eye is **fixed**.

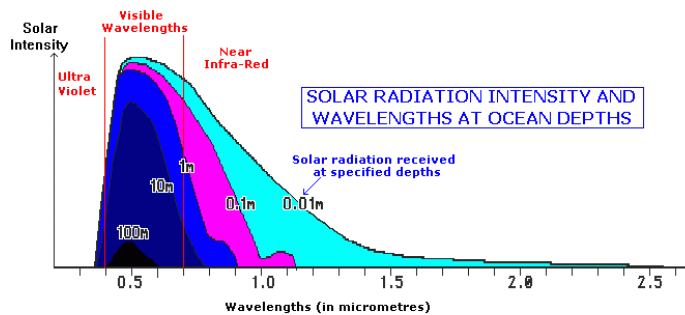
**James Clerk Maxwell** (1854) contemplated the way the world would look to a fish based on the geometry of a fish's very short focal length crystalline lens and Robert Wood (1906) "*interested to ascertain how the external world looks to the fish*", created the first **fish-eye camera** by putting a camera underwater (middle figure). He then created a horizontal water camera (figure on right) that "*gives us a good idea of how the visitors at an aquarium look to the fishes.*" Lenses that capture rays coming from **ultra wide angles** are known as fisheye lenses.



Fish-eye lenses are available for smart phones for less than ten dollars.

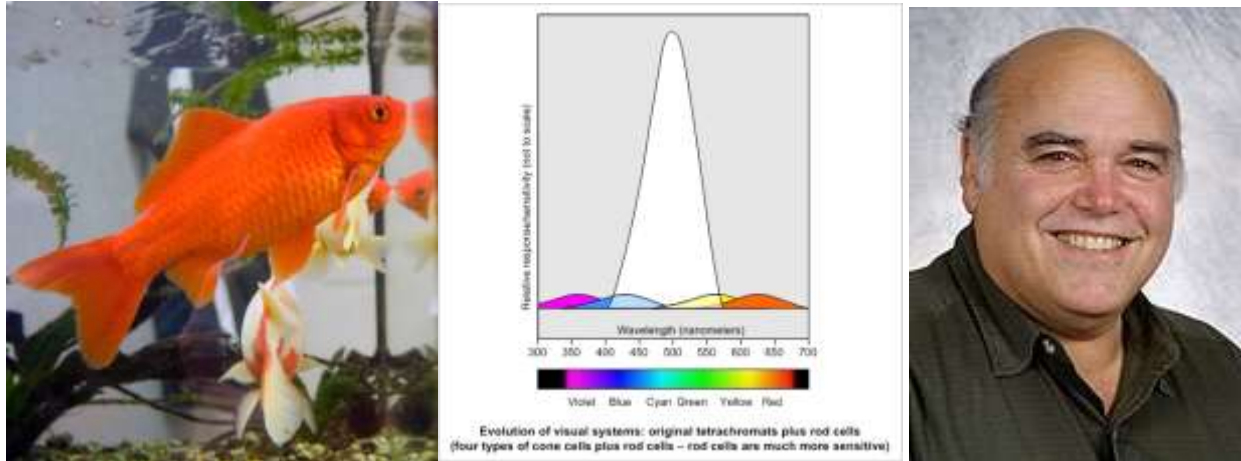


Sunlight traveling into water becomes bluer with depth since the longer (redder) wavelengths get absorbed by the water.

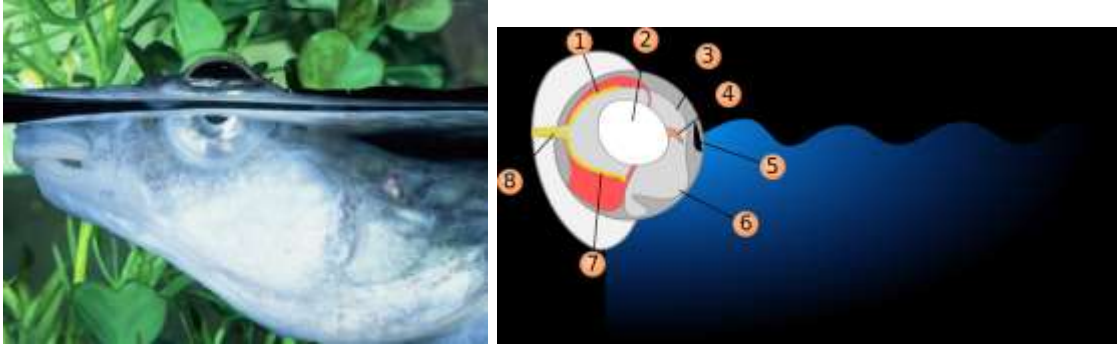


The solar radiation 'envelope' penetrates the ocean to 100 metres at visible wavelengths but to much shallower depths as wavelength increases. Back radiation in the far infra-red from the Greenhouse Effect occurs at wavelengths centred around 10 micrometres, well off the scale of this chart, and cannot penetrate the ocean beyond the surface 'skin'.

Consequently, while fish living in shallow water have **retinas** with mostly **cones** that give **photopic** color vision, fish living in deeper water have **retinas** with mostly **rods** that give **scotopic** vision. The retinas of fish living in shallow waters are also sensitive to **ultraviolet light**. **Goldfish** are **tetrachromats** with four different types of cones, including ultraviolet, blue, green, and red. Goldfish are able to see colors ranging from infrared through the visible range to the ultraviolet. Ellis Loew (Cornell) studies vision in fish.

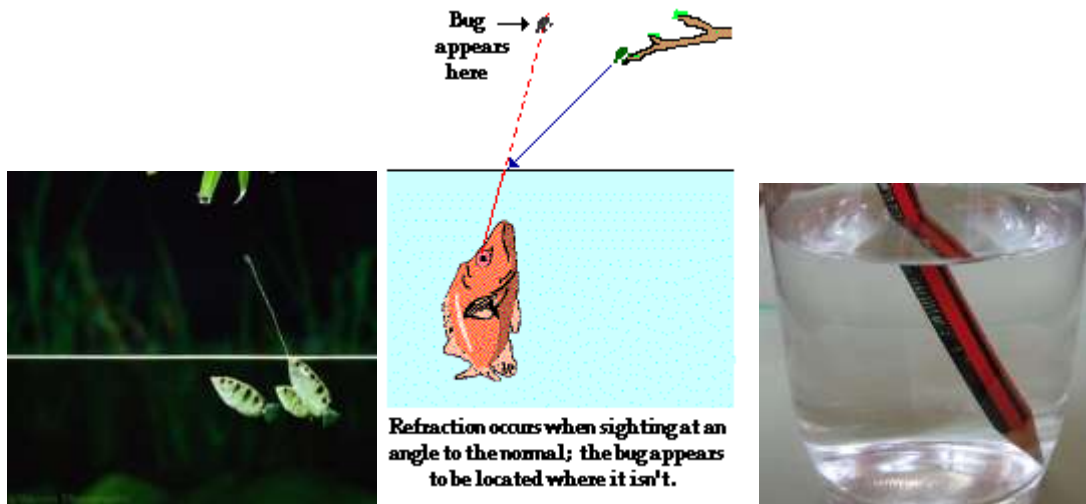


The **four-eyed fish** (*Anableps*) are visionaries among fish. They have eyes on each side of their head that are divided into two parts that can be used simultaneously. The top part of the eye is good for catching insects in the **air** to eat. The bottom part of the eye is good for looking for predators under **water**. A part of the retina is used for water vision (1) and another part is used for air vision (7). The curvature of the crystalline lens (2) is greater for light coming through the water pupil (6) than it is for the light coming through the air pupil (3) as a result of the need for greater refracting or dioptric power for focusing light rays coming from water ( $n = 1.333$ ) compared with light rays coming from air ( $n = 1$ ).



<http://www.youtube.com/watch?v=ZPR7aqzvHtA>

The **archerfish** (*Toxotes*) are the sharpshooters among fish. They are able to spit at insects up to three meters above the surface of the water and knock them into the water so they can eat them. This means that the archerfish is able to compensate for the bending of light that occurs at the air water interface and is described by the **Snel-Descartes Law**. The archerfish's brain fixes the refraction illusion unlike ours when we see a broken pencil at a water air interface!





**Cave fish** (*Amblyopsis*) live in the dark and have no need for eyes. Some are completely blind and some can only detect the difference between light and dark.



The eyes of **flashlight fish** light up as a result of symbiotic **bioluminescent bacteria** that are contained in **photophores** below each eye.

The light is produced constantly but the fish flashes the light two to three times a minute by rotating the photophore in the eye socket. We



will talk about deep ocean-dwelling fish that make use of bioluminescent bacteria for **camouflage**, communication, and for catching prey later this semester.

Frogs are **amphibians** that begin their life as tadpoles swimming with their **eyes underwater** and then spend most of their life with their **eyes above water**. During the metamorphosis, the **cornea** becomes **smoother** and **rounder** and **eyelids** and **tear ducts**, which keep the cornea clean and moist, form. These features that **do not** occur in fish eyes that are surrounded by water. The crystalline lens of frogs, like that of fish is rigid, and accommodation results from the back and forth movement of the lens and not from a change in its shape. During the metamorphosis, the eyes are positioned near the top of the head where they provide the **stereo vision necessary for catching food** as well as **peripheral vision necessary for seeing predators**.



The red-eyed tree frog (*Agalychnis callidryas*) has a spectacular iris color. Red eyes also occur in albino frogs that lack pigmentation in the iris.



**Reptiles**, unlike fishes and amphibians have a retina with a **fovea** that allows them to **resolve fine details**. Reptilian eyes accommodate as a result of changing the shape of the crystalline lens. Unlike other animals, the **crystalline lens** of chameleons at rest is a **diverging lens** that reduces the refracting or dioptric power of the eye given by the **converging lens cornea** when a distant object is focused on the retina. Chameleon eyes are mounted on **turrets** on both sides of the head. The two eyes turn independently, allowing chameleons to see in two different directions at once. Diurnal reptiles that are active during the



day have **cone-rich retinas** for **photopic color vision**, while nocturnal and burrowing reptiles have **rod-rich retinas** for **scotopic vision**.

**Birds** have a variety of eyes that let them see with great acuity. The ostrich has the second largest (2 inches in diameter) eye among animals, second only to the giant squid. While a large eye is useful to a squid for its **light collecting ability** in dimly-lit habitats, the large eye is useful to an ostrich for the **better visual acuity** it provides.



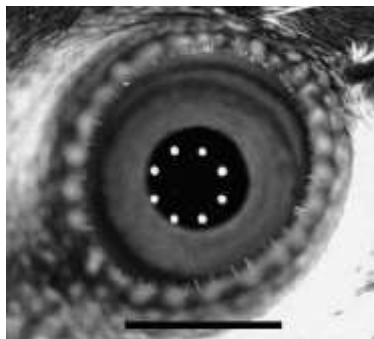
Birds that need good vision when in air, with a refractive index of 1 and water with a refractive index of 1.33-1.34 have

the ability to change the curvature of **both** their **cornea** and their **crystalline lens** when they **accommodate**. **Cormorants** (*Phalacrocorax carbo sinensis*) and **gannets** (*Morus serrator*)



**accommodate** with their **corneas above water** where the refractive index of air is one and

**accommodate** with their **crystalline lens** when they are **underwater** ( $n = 1.33-1.34$ ) and the cornea no longer has much refractive or dioptric power. Howard Howland (Cornell) studies bird eyes.



**Diurnal birds** have cone-dominated retinas and excellent **photopic color vision** while **nocturnal birds**, such as **owls** have **rod-dominated retinas** and **scotopic vision**. In fact the fovea of owls is also rod-dominated. Owls also have large eyes with good light-capturing ability for hunting at night. They also have a **tapetum lucidum** for reflecting back to the photoreceptor pigments any light that had not been captured on the first pass. The two forward-facing eyes give them good stereo vision. Owls cannot move their eyes in their sockets, but they can see in many directions by turning their neck 270 degrees in either direction.



**Raptors** are birds of prey that can have a piercing stare are a result of the large eyebrow above their eye that shields the eye from the direct rays of the sun. **Raptors** also have great visual acuity compared with humans. Their greater visual acuity results from **cones** in the **fovea** that are **thinner** and **more numerous** than the cones of humans. In fact, raptors have two highly developed foveas in each retina. When a **bifoveate** raptor initially sees its prey it does not fly directly towards the prey, but spirals towards it, with its head straight relative to the body but at an angle to its prey. The position of the head reduces air resistance and puts the central fovea of one eye (**monocular vision**) in

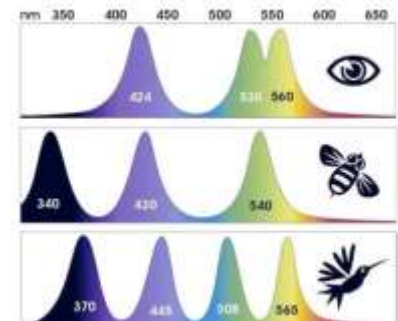


the line of sight. As the raptor approaches its prey, the flight path becomes more direct and the temporal foveas are used in order to enhance the **stereo vision** necessary for precision aim.

**Predatory birds**, such as the **peregrine falcon**, tend to have large forward facing eyes with a small field of view but **stereo vision** with good depth perception, while **prey species**, such as **pigeons**, have **small, flat, laterally-placed** eyes that are capable of **surveying a wide area**, but with monocular vision and little or no depth perception.



Birds that pollinate flowers are typically **tetrachromats** and have ultraviolet, blue, green and red cones. These birds also have carotenoid pigment-containing oil droplets that act like filters in front of the cones, perhaps creating even more types of cones. Some birds may be **pentachromic** as a result of the differential filtering of the oil droplets over the four types of opsin photoreceptors. While the ability to **discriminate colors** may be an advantage, the downside is reduced visual acuity. Do you know why?



The **visual spectrum of diurnal bird pollinators** is enhanced in the **red** compared with the visual spectrum of bees. Consequently, red and orange flower are more likely to be pollinated by birds than by bees. (Some **butterflies** are tetrachromatic and also see in the red). We will talk about flower color and pollinator vision later in the semester.



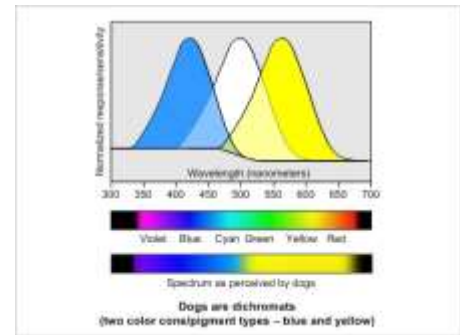
**Predatory mammals**, including **cheetahs**, **dogs** and **cats** have their camera eyes placed in the front of their head to give **binocular vision** with good **depth perception**. Predatory mammals also have retinas with **foveas** that give good **visual acuity**. **Accommodation** of mammalian eyes results from a change in the shape and a **decrease in the focal length** of the crystalline lens when viewing nearby objects.



**Grazing animals** , such as a **horse** or antelope that might serve as a meal for predators, have camera eyes placed on the side of their heads to give a **wide field of view** (350°, 65 ° of binocular vision and 285 ° of monocular vision) with little depth perception. Horses have little power of accommodation.



Most terrestrial **mammals**, including **dogs**, **cats** and **bulls** are **dichromats** and have poor color vision. Exceptions include prairie dogs, squirrels, monkey, apes and humans, which are all **trichromats**.

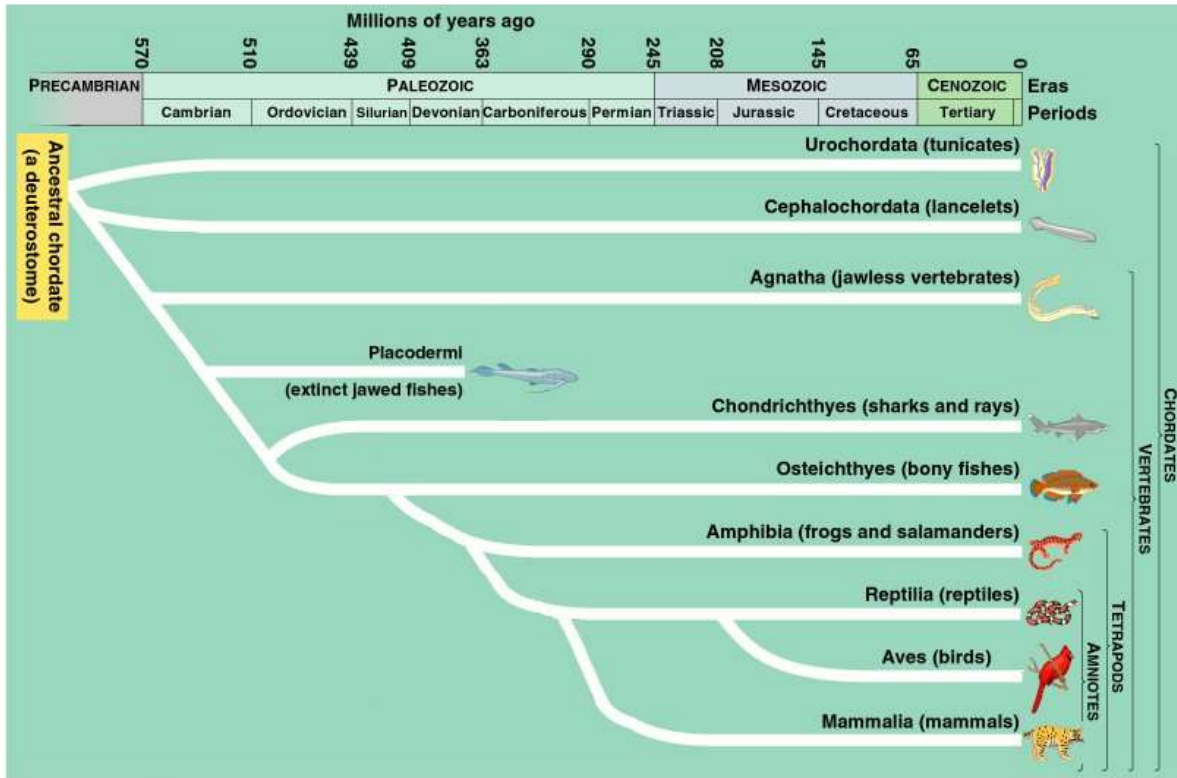


**Nocturnal** mammals have rod-rich retinas for scotopic vision and a **tapetum lucidum** to help them see in the dark. **Reflection** of light from the **tapetum lucidum** is the cause of **eyeshine** (in dogs, cats and alligators).



We see the **variation** in the placement of the eyes, the size of the eyes, the proportion of focusing that is due to the cornea and crystalline lens, the mechanism of accommodation, the ability of the pupil to contract and dilate, the ratio of rods

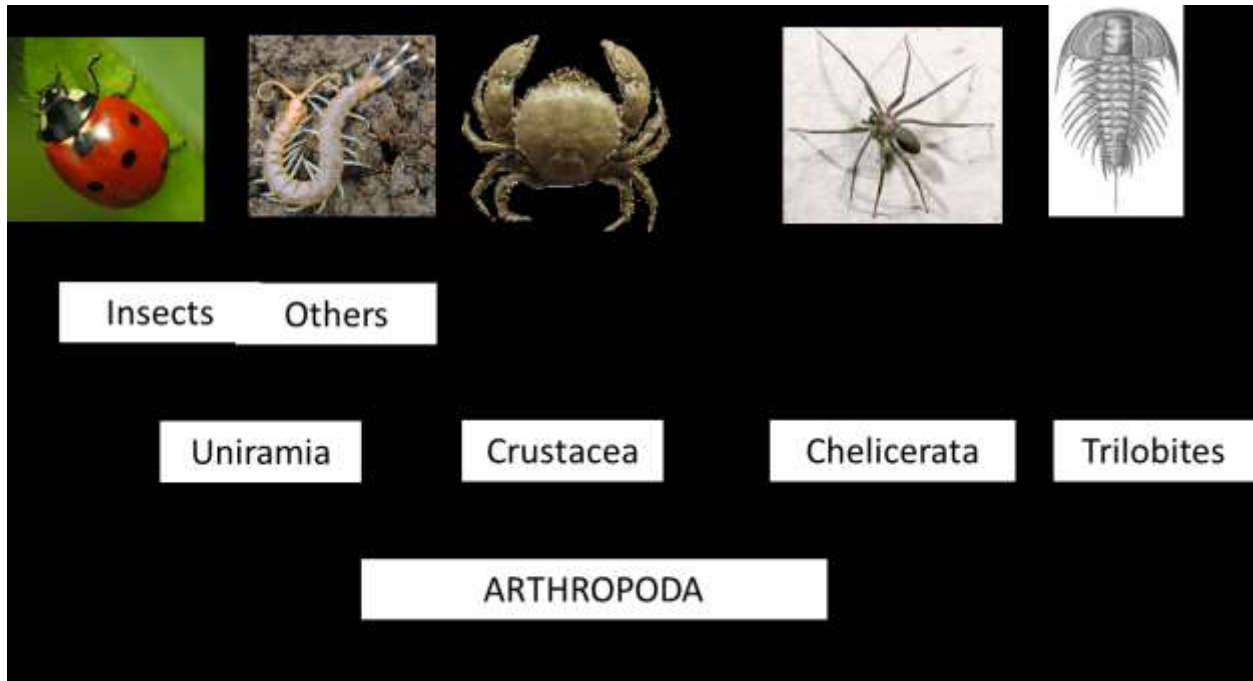
(scotopic vision) to cones (photopic color vision) in the retina, and the spectral sensitivity of the cones. We can see that the eyes of fish, amphibians, reptiles, birds, and mammals have evolutionary adaptations and/or designs that **suit the life style of the beholder**. What are the **causes** of the diversity seen in the vertebrate eye?



© 1999 Addison Wesley Longman, Inc.

Before answering that question, let's look at the **eyes** of the **arthropods** , which include the Trilobites, the Arachnids, the Crustaceans, and the Insects.





Five hundred and forty million years ago, in the **Cambrian**, the **trilobites** may have been the first animals to see the world. They had **compound eyes** like their relatives, the insects and crustaceans.

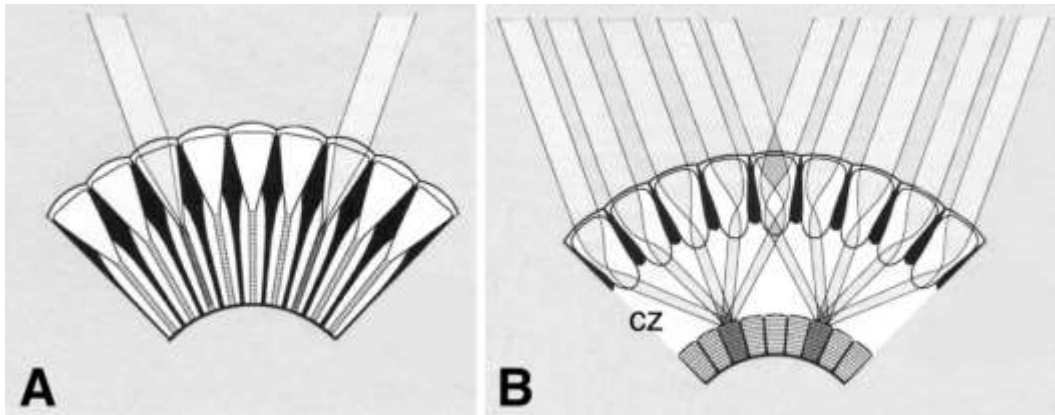


**Compound eyes** are made out of many units called **ommatidia**. They function to give a **wide field** and **rapid** responses, which is why it is hard to swat a fly. A compound eye typical of **diurnal insects** such as **houseflies**, **dragonflies** and **butterflies** is of the **apposition type (A)** where **light reaches the photoreceptors exclusively from the small corneal lens located directly above**.



Generally speaking, each cornea forms an inverted image of the object, but the photoreceptors at the base of each **ommatidium** measures only the brightness of the small region of space collected by the cornea. The erect image seen by the insect is a mosaic of the individual brightness levels of each field of view.

Nocturnal insects such as cockroaches and moths that live in limiting light conditions have a **superposition type (B)** of compound eye. The sensitivity to light is increased by having hundreds to thousands of corneal facets that collect and focus the light towards single photoreceptors in the retina.



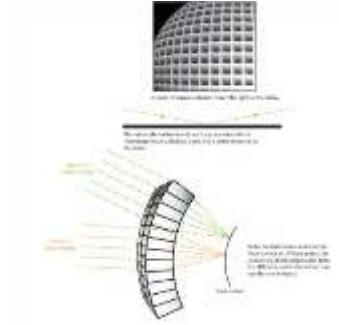
**Robert Hooke** (1665) published his observation of the compound eyes of a grey drone fly and the eyes of other insects in his *Micrographia*. We will see the *Micrographia* when we go to Kroch Library later this semester.



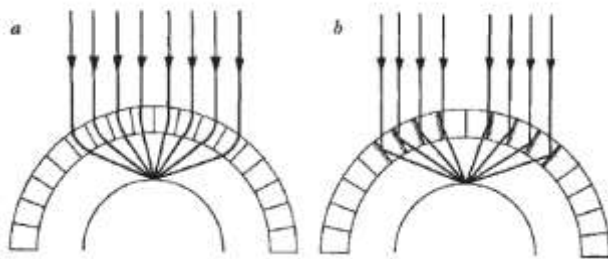
**Demonstration:** Observe a house fly's apposition type compound eye under the dissecting microscope.



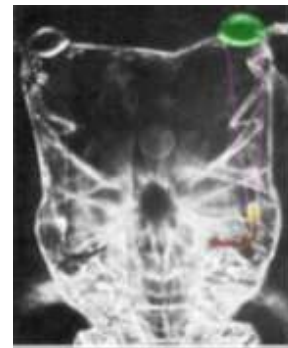
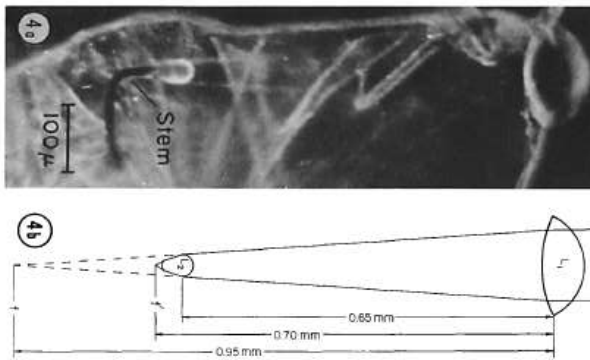
**Crustaceans**, such as **lobsters**, shrimp and crayfish also have **superposition type compound eyes**. However, in their case, the light is directed down the **ommatidium** according to the **law of reflection**, not the law of refraction.



**Fig. 1** Superposition image formation (a) by refraction (modified from Exner) and (b) by reflection.



Some **copepods**, which are also crustaceans, can have eyes that can only be described as **telescopes!**

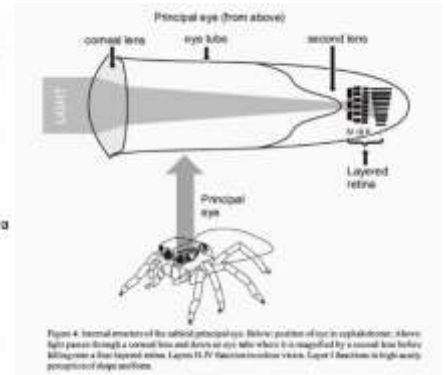
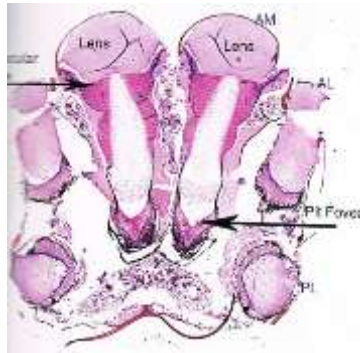


**Spiders** are **arthropods** that typically have eight simple eyes. Some of the eyes look forward, the rest scan the peripheries. As in other land animals, the

**EYE ARRANGEMENTS OF THREE COMMON SPIDER FAMILIES**



cornea is the main refracting system in spider eyes and the optical system is reminiscent of a **refracting telescope**.



The **jumping spider** (*Portia fimbriata*), which can jump twenty body lengths, and the **ogre-faced net-casting spider** (*Dinopis subrufa*) have very high



resolution eyes with a limiting resolution only 2.4 arc minutes that allows them to hunt and successfully capture their prey. Some spiders are diurnal and others are nocturnal hunters. <https://www.youtube.com/watch?v=Wt4LpZa3iFs>

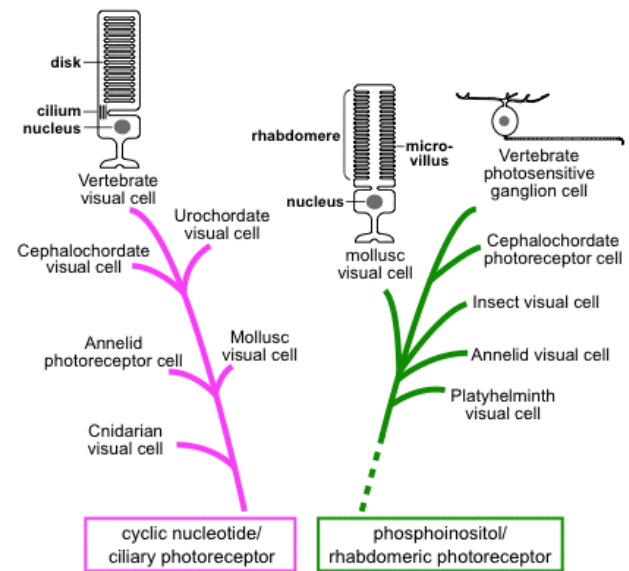
Nocturnal spiders have relatively large eyes and well developed tapeta to allow them to hunt at dusk and in moonlight. Here is a picture of eyeshine from a **wolf spider**.



Web-spinning spiders whose food comes to them, have eyes with low resolving power.



There is diversity in the type of cells that act as photoreceptors in animals. In the vertebrate line, the rods and cones are modified **cilia**. In all other animals, the photoreceptor cells can be either modified cilia or modified **microvilli**. Later in the semester we will talk about **melanopsin**, a pigment that is in the human eye that does not participate in image formation, but in sensing the light-dark cycle involved in our sleep-wake cycle. While the rod (**rhodopsin**) and cone (**photopsin**) pigments are found in **ciliary**-like cells, the **melanopsin** is found in **microvilli**-like cells.



As we see there is a great diversity in eyes in the animal world and each form is suited to the life style of the beholder. Optically speaking, there are as many ways that animal eyes use light to form images as there are optical instruments. Animals use **pinholes**, **converging** and **diverging lenses** and **mirrors** to produce images of the external world. We have discussed the eyes of diurnal and nocturnal animals as well as the eyes of aquatic and terrestrial animals and the design constraints. Amazed by the design of eyes, **William Paley**



(1802) wrote in *Natural Theology*, “every indication of contrivance, every manifestation of design, which existed in the watch, exists in the works of nature; with the difference, on the side of nature, of being greater and more, and that in a degree which exceeds all computation. I mean that the contrivances of nature surpass the contrivances of art, in the complexity, subtility, and curiosity of the mechanism; and still more, if possible, do they go beyond them in number and variety; yet, in a multitude of cases, are not less evidently mechanical, not less evidently contrivances, not less evidently accommodated to their end, or suited to their office, than are the most perfect productions of human ingenuity.

*I know no better method of introducing so large a subject, than that of comparing a single thing with a single thing; an eye, for example, with a telescope. As far as the examination of the instrument goes, there is precisely the same proof that the eye was made for vision, as there is that the telescope was made for assisting it. They are made upon the same principles; both being adjusted to the laws by which the transmission and refraction of rays of light are regulated. I speak not of the origin of the laws themselves; but such laws being fixed, the construction, in both cases, is adapted to them. For instance; these laws require, in order to produce the same effect, that the rays of light, in passing from water into the eye, should be refracted by a more convex surface, than when it passes out of air into the eye. Accordingly we find that the eye of a fish, in that part of it called the crystalline lens, is much rounder than the eye of terrestrial animals. What plainer manifestation of design can there be than this difference? What could a mathematical-instrument-maker have done more, to show his knowledge of his principle, his application of that knowledge, his suiting of his means to his end; I will not say to display the compass or excellence of his skill and art, for in these all comparison is indecorous, but to testify counsel, choice, consideration, purpose?”*

**Charles Darwin** (1859) in *The Origin of Species* proposed that the eye did not need a creator, but evolved by natural selection. *“To suppose that the eye, with all its inimitable contrivances for adjusting the focus to different distances, for admitting different amounts of light, and for the correction of spherical and chromatic aberration, could have been formed by natural selection, seems, I freely confess, absurd in the highest possible degree.*



*Yet reason tells me, that if numerous gradations from a perfect and complex eye to one very imperfect and simple, each grade being useful to its possessor, can be shown to exist; if further, the eye does vary ever so slightly, and the variations be inherited, which is certainly the case; and if any variation or modification in the organ be ever useful to an animal under changing conditions of life, then the difficulty of believing that a perfect and complex eye could be formed by natural selection, though insuperable by our imagination, can hardly be considered real. How a nerve comes to be sensitive to light, hardly concerns us more than how life itself first originated; but I may remark that several facts make me suspect that any sensitive nerve may be rendered sensitive to light, and likewise to those coarser vibrations of the air which produce sound.*

*In looking for the gradations by which an organ in any species has been perfected, we ought to look exclusively to its lineal ancestors; but this is scarcely ever possible, and we are forced in each case to look to species of the same group, that is to the collateral descendants from the same original parent-form, in order to see what gradations are possible, and for the chance of some gradations having been transmitted from the earlier stages of descent, in an unaltered or little altered condition. Amongst existing Vertebrata, we find but a small amount of gradation in the structure of the eye, and from fossil species we*

*can learn nothing on this head. In this great class we should probably have to descend far beneath the lowest known fossiliferous stratum to discover the earlier stages, by which the eye has been perfected.*

*In the Articulata we can commence a series with **an optic nerve merely coated with pigment**, and without any other mechanism; and from this low stage, numerous gradations of structure, branching off in two fundamentally different lines, can be shown to exist, until we reach a moderately high stage of perfection. In certain crustaceans, for instance, there is a double cornea, the inner one divided into facets, within each of which there is a lens-shaped swelling. In other crustaceans the transparent cones which are coated by pigment, and which properly act only by excluding lateral pencils of light, are convex at their upper ends and must act by convergence; and at their lower ends there seems to be an imperfect vitreous substance. With these facts, here far too briefly and imperfectly given, which show that **there is much graduated diversity in the eyes of living crustaceans**, and bearing in mind how small the number of living animals is in proportion to those which have become extinct, I can see no very great difficulty (not more than in the case of many other structures) in believing that natural selection has converted the simple apparatus of an optic nerve merely coated with pigment and invested by transparent membrane, into an optical instrument as perfect as is possessed by any member of the great Articulate class.*

*He who will go thus far, if he find on finishing this treatise that large bodies of facts, otherwise inexplicable, can be explained by the theory of descent, ought not to hesitate to go further, and to admit that a structure even as perfect as the eye of an eagle might be formed by natural selection, although in this case he does not know any of the transitional grades. His reason ought to conquer his imagination;*



*though I have felt the difficulty far too keenly to be surprised at any degree of hesitation in extending the principle of natural selection to such startling lengths.*

*It is scarcely possible to avoid comparing the eye to a telescope. We know that this instrument has been perfected by the long-continued efforts of the highest human intellects; and we naturally infer that the eye has been formed by a somewhat analogous process. But may not this inference be presumptuous? Have we any right to assume that the Creator works by intellectual powers like those of man? If we must compare the eye to an optical instrument, we ought in imagination to take a thick layer of transparent tissue, with a nerve sensitive to light beneath, and then suppose every part of this layer to be continually changing slowly in density, so as to separate into layers of different densities and thicknesses, placed at different distances from each other, and with the surfaces of each layer slowly changing in form. Further we must suppose that there is a power always intently watching each slight accidental alteration in the transparent layers; and carefully selecting each alteration which, under varied circumstances, may in any way, or in any degree, tend to produce a distincter image. **We must suppose each new state of the instrument to be multiplied by the million; and each to be preserved till a better be produced, and then the old ones to be destroyed. In living bodies, variation will cause the slight alterations, generation will multiply them almost infinitely, and natural selection will pick out with unerring skill each improvement. Let this process go on for millions on millions of years; and during each year on millions of individuals of many kinds; and may we not believe that a living optical instrument might thus be formed as superior to one of glass, as the works of the Creator are to those of man?***

*If it could be demonstrated that any complex organ existed, which could not possibly have been formed by numerous, successive, slight modifications, my*

*theory would absolutely break down. But I can find out no such case. No doubt many organs exist of which we do not know the transitional grades, more especially if we look to much-isolated species, round which, according to my theory, there has been much extinction. Or again, if we look to an organ common to all the members of a large class, for in this latter case the organ must have been first formed at an extremely remote period, since which all the many members of the class have been developed; and in order to discover the early transitional grades through which the organ has passed, we should have to look to very ancient ancestral forms, long since become extinct.”*

In the *Blind Watchmaker*, Richard Dawkins (1986) discounted Paley and supported Darwin, “*Paley’s argument is made with passionate sincerity and is informed by the best biological scholarship of his day, but it is wrong, gloriously and utterly wrong. The analogy between telescope and eye, between watch and living organism, is false. All appearances to the contrary, the only watchmaker in nature is the blind forces of physics, albeit deployed in a very special way. A true watchmaker has **foresight**: he designs his cogs and springs, and plans their interconnections, with a future purpose in his **mind’s eye**. Natural selection, the blind, unconscious, automatic process which Darwin discovered, and which we now know is the explanation for the existence and apparently purposeful form of all life, has no purpose in mind. It has no mind and **no mind’s eye**. It does not plan for the future. It has **no vision, no foresight, no sight at all**. If it can be said to play the role of the watchmaker in nature, it is the **blind** watchmaker.*” Dawkins wrote in the *New York Times* (April 9,1989), “*It is absolutely safe to say that if you meet somebody who claims not to believe in evolution, that person is ignorant, stupid or insane (or wicked, but I’d rather not*



consider that).” Richard Dawkins demonstrates the evolution of the eye in this short video: <http://www.youtube.com/watch?v=Nwew5gHoh3E>

Today, scientists are emphasizing the **un-intelligent design** of the eye as evidence for evolution by natural selection. Neil deGrasse Tyson (2009) wrote in *The Perimeter of Ignorance*, “The eye is often held up as a marvel of biological engineering. To the astrophysicist, though, **it's only a so-so detector**. A better one would be much more sensitive to dark things in the sky, and to all the invisible parts of the spectrum. How much more breathtaking sunsets would be if we could see ultraviolet and infrared. How useful it would be if, at a glance, we could see every source of microwaves' in the environment, or know which radio station transmitters were active. How helpful it would be if we could spot police radar detectors at night.



To deny or erase the rich, colorful **history** of scientists and other thinkers who have invoked divinity in their work would be intellectually dishonest. Surely there's an appropriate place for intelligent design to live in the academic landscape. How about the **history** of religion? How about philosophy or psychology? The one place it doesn't belong is the science classroom.”

Trevor Lamb (2011) wrote in *The Evolution of the Eye*, “For all the ingenious features evolution built into the vertebrate eye, there are a number of decidedly inelegant traits. For instance, the retina is inside out, so light has to pass through the whole thickness of the retina—through the intervening nerve fibers and cell bodies that scatter the light and degrade image quality—before reaching the light-sensitive photoreceptors. Blood vessels also line the inner surface of the retina, casting unwanted shadows onto the photoreceptor layer. The



*retina has a blind spot where the nerve fibers that run across its surface congregate before tunneling out through the retina to emerge behind it as the optic nerve. The list goes on and on.*

*These defects are by no means inevitable features of a camera-style eye because octopuses and squid independently evolved camera-style eyes that do not suffer these deficiencies. Indeed, if engineers were to build an eye with the flaws of our own, they would probably be fired. **Considering the vertebrate eye in an evolutionary framework reveals these seemingly absurd shortcomings as consequences of an ancient sequence of steps, each of which provided benefit to our long-ago vertebrate ancestors even before they could see. The design of our eye is not intelligent—but it makes perfect sense when viewed in the bright light of evolution.***

More recently, Brian Ford (2013) wrote in *Debunking the Myth of Intelligent Design*, “The structure of the eye is widely cited as an example of intelligent design because, say the proponents, until an eye has been fully formed it simply cannot function. Thus, evolution vaguely in the direction of a fully developed eye could not have taken place unless there were a designer at work, who envisaged what the final result might be. This does not stand scrutiny. First, there are eyes of every type in differing animals. Some are simple (like those of spiders) whereas others are complex (like those of flies). Some eyes (including ours) have lenses, whereas others, like those of a squid [sic], work wonderfully with no lens at all. Any designer, having worked out a perfect organ of sight, would install it in everything that needed an eye. Running countless different types of eyes in parallel is the height of inefficiency.



*It is the mammalian eye that provides unambiguous evidence. No designer could have made such a curious mistake than in contriving our eyes, They're assembled backwards, and afflict us all with inferior vision.... This all reveals to us that humans were not designed by some supreme being. As a product of design we are excruciating inefficient, metabolically muddled, functionally futile and conceptually confused. **It would take a designer of unimaginable and perverse stupidity to make so many obvious mistakes. God is portrayed in many ways by world religions, but not one of them insists that their deity is an idiot....So we can see that the design of humans is idiotic and riddled with problems that make people suffer. If you wish to seek intelligence in the way living systems work, then there is no point in seeking inspiration from God.***

What do *you think*? Natural selection? Godly design?

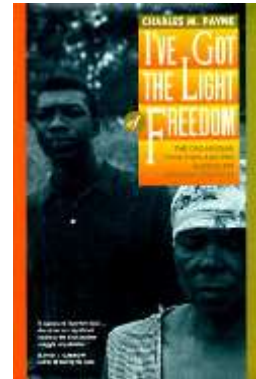
The motto of the Royal Society of London is *Nullius in Verba*, which roughly translates as “take no one’s word for it.” The motto expresses the Society’s belief in the importance of **seeing for one’s self and not bowing to external authority.**



The Royal Society's motto 'Nullius in verba' roughly translates as 'take nobody's word for it'. It is an expression of the determination of Fellows to withstand the domination of authority and to verify all statements by an appeal to facts determined by experiment.

**What are our eyes for?** Jacob Helen Campbell (1892), author of *Darkness and Daylight*, and Jacob Riis (1890,1902,1903), author of *How the Other Half Lives* and *The Battle with the Slum*, used their eyes to see injustice.

<http://www.authentichistory.com/1898-1913/2-progressivism/2-riis/index.html> They shared their sight with us by way of flashlight-lit photographic images that showed the dark side of affluent society. Likewise, people in the civil rights movement illuminated what was wrong with America with the light of freedom, and made it better.



of



### **What do we learn about being human from studying eyes and vision?**

Viktor Frankl (1955) wrote in *The Doctor and the Soul*:

*“If we present man with a concept of man which is not true, we may well corrupt him. When we present him as an automation of reflexes, as a mind-machine, as a bundle of instincts, as a pawn of drives and reactions, as a mere product of instincts, heredity, and environment, we feed the despair to which man is, in any case, already prone. I became acquainted with the last stages of corruption in my second concentration camp in Auschwitz. The gas chambers of Auschwitz were the ultimate consequence of the theory that man is nothing but the product of heredity and environment—or, as the Nazis liked to say, of ‘Blood and Soil.’ I am absolutely convinced that the gas chambers of Auschwitz, Treblinka, and Maidanek were ultimately prepared not in some Ministry or other in Berlin, but rather at the desks and in the lecture halls of nihilistic scientists and philosophers.”*



[http://www.ted.com/talks/viktor\\_frankl\\_youth\\_in\\_search\\_of\\_meaning](http://www.ted.com/talks/viktor_frankl_youth_in_search_of_meaning)

## Blowin in the Wind

by Bob Dylan (1962)

*How many roads must a man walk down  
Before you call him a man?  
Yes, 'n' how many seas must a white dove sail  
Before she sleeps in the sand?  
Yes, 'n' how many times must the cannonballs fly  
Before they're forever banned?  
The answer, my friend, is blowin' in the wind  
The answer is blowin' in the wind*

*How many years can a mountain exist  
Before it's washed to the sea?  
Yes, 'n' how many years can some people exist  
Before they're allowed to be free?  
**Yes, 'n' how many times can a man turn his head  
Pretending he just doesn't see?**  
The answer, my friend, is blowin' in the wind  
The answer is blowin' in the wind*

*How many times must a man look up  
Before he can see the sky?  
Yes, 'n' how many ears must one man have  
Before he can hear people cry?  
Yes, 'n' how many deaths will it take till he knows  
That too many people have died?  
The answer, my friend, is blowin' in the wind  
The answer is blowin' in the wind*

